

# Loadtest: Automation of Continuous Flight Auger Piling

LOADTEST provides expert independent service in the field of piling rig instrumentation. This information sheet deals specifically with piling rig instrumentation and the full automation of continuous flight auger piling process.

Continuous Flight Auger (CFA) or auger cast piling has two specific phases of operation. Firstly, the digging phase where the auger rotates and penetrates the ground to the desired depth. Secondly, the construction phase where the auger is withdrawn whilst concrete or grout is pumped through the hollow auger to replace the removed spoil. Both aspects of the automated CFA process are patented.

## Advantages of automation

Reliable construction of this type of pile is essential, both for design considerations and from a commercial viewpoint.

The designer needs to be assured that the piles installed are of the correct diameter and length, of reliable integrity and that the soil has not been unduly disturbed by the construction process.

Commercially, correct and automated construction of the piles on a given site can make substantial savings over piles constructed manually and without due consideration of the piling process.

By drilling the pile efficiently and by controlling the supply of concrete to the auger during construction, both the design and commercial aspects of the piling process are met. Precision monitoring of instrumentation is essential and data storage and retrieval allows for checking of the whole construction process.

A further benefit is from time saved, both per pile in construction time and from reduced breakdown of equipment induced by incorrect drilling techniques.

## Reliable Installation and Construction

Reliable installation of the pile is influenced by a number of factors. Firstly, the ground surrounding the excavation should not be overly disturbed. It is essential to maintain the correct penetration rate and torque on the auger to ensure the efficiency of the drilling process and that the auger string is efficient at removing the spoil from the excavation.

Secondly, sufficient concrete should be delivered through the auger so as to prevent the ingress of soil from the walls of the excavation that would otherwise contaminate the concrete cross-section. It is essential to ensure that the tip of the auger remains immersed in concrete at all times during the construction phase. Pulling the auger too quickly, with respect to concrete volume delivery, may result in poor integrity of the piles. Pulling too slowly may result in high wastage of concrete and oversupply.

By having the piling process under computer control, the reliability and integrity of the pile can be greatly improved.

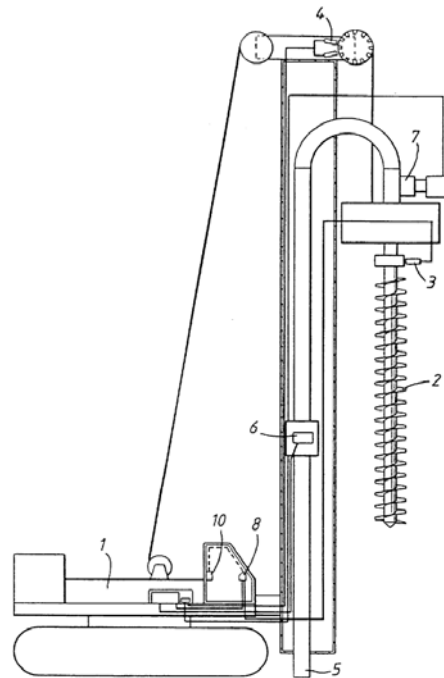

## Instrumentation

Piling rig design is different for every manufacturer or supplier but the essential components for CFA piling instrumentation are outlined in the schematic below.

1. Piling Rig or Mounting Crane
2. Hollow stem flight auger
3. Rotation encoder mounted on the rotary head or table
4. Depth encoder
5. Concrete supply line
6. Electromagnetic flow meter
7. Pressure sensor
8. Operating computer
9. Display unit
10. Data acquisition unit

An instrumentation record for each pile constructed is available on site and these can be provided to the client as evidence of correctly constructed piles.

## Computer Control

### Drilling Phase:

By placing the drilling process under computer control it is possible to advance of the auger according to a specific predetermined number of auger revolutions per metre of penetration. It is possible to achieve very fine control of the auger by this means, enabling almost continuous penetration of the auger at the desired rate of advance. In contrast, this process, under manual control, permits only coarse adjustment by the rig operator.

The computer control also ensures that the auger is not allowed to advance when ground conditions are such that the maximum rig torque is developed. This helps to prevent the auger from reaching a stage where it becomes stuck in the ground with no excess torque from the rotary table available to initiate soil shearing.

### Construction Phase:

By controlling the rate of withdrawal of the auger as a function of the concrete supply, or vice versa, and knowing the diameter of the auger, it is possible to calculate and supply the minimum theoretically required volume of concrete to form a structurally sound pile. A pre-determined oversupply of concrete is calculated in order to provide additional structural soundness. The amount of oversupply will be determined principally by the site ground conditions.

Correct oversupply of concrete helps to ensure the excavation is totally filled and allows for minor localised disturbances in the pile wall in the most efficient manner. It is important to keep the tip of the auger immersed in the pile concrete during the withdrawal phase in order to prevent collapse of the pile bore and subsequent soil contamination of the concrete shaft.

Withdrawal of the auger is achieved by means of interfacing the computer with an electronically controlled hydraulic valve within the piling rig to control the rate of auger extraction with respect to correct concrete oversupply.

Every pile constructed can therefore be produced in the most efficient and timely manner using the optimum volume of concrete.

## Database management tool

From the data recorded, complete pile installation records can be printed and the data obtained during the piling process can be used for further analysis and storage in a database system.

This information can then be made available as a management tool for the analysis of individual rig performance, operator performance, contract performance and allowing review of the overall company performance. As a consequence, the entire CFA operation can be reviewed in detail by statistical analyses, allowing management to make changes to piling practices and ensuring maximum efficiency from each rig.

## Benefits of Automation

**Cost Savings:** Concrete oversupply is greatly reduced making cumulative savings. Contract performance is greatly enhanced.

**Consistency of piles:** As each pile is constructed to similar installation parameters, piles across a given site should be of a consistent construction, reducing also the potential of differential settlements.